

Specification Sheet for Scissor Blind Double Drop 1066mm BLSC1066D

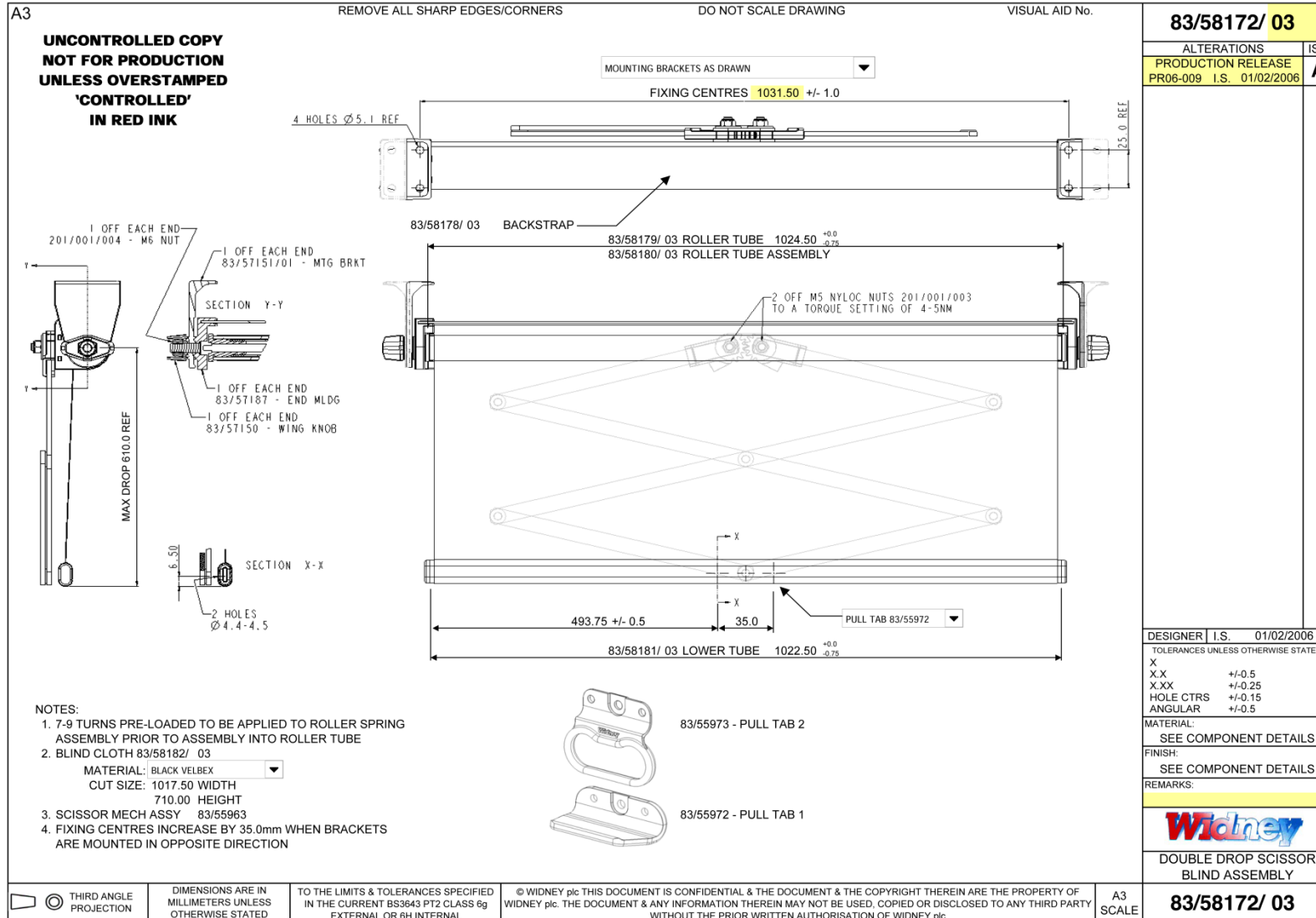

A3 REMOVE ALL SHARP EDGES/CORNERS DO NOT SCALE DRAWING VISUAL AID No.

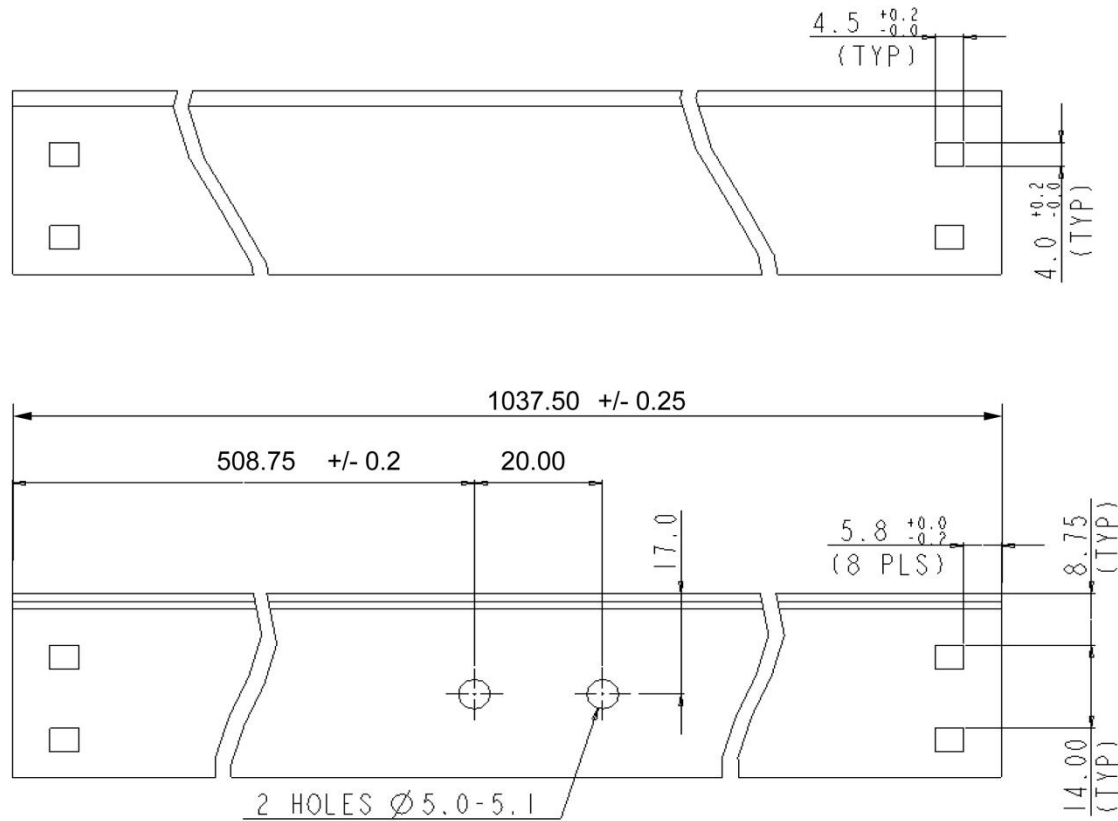

83/58178/ 03	
ALTERATIONS	ISS
PRODUCTION RELEASE PR06-009 I.S. 01/02/2006	A
DESIGNER I.S. 01/02/2006	
TOLERANCES UNLESS OTHERWISE STATED	
X	
X.X	+/-0.5
X.XX	+/-0.25
HOLE CTRS	+/-0.15
ANGULAR	+/-0.5
MATERIAL: SECTION 29/56852	
FINISH: BLACK POWDER COAT 6.02	
REMARKS:	
Widney	
ROLLED STEEL BACKSTRAP	
83/58178/ 03	

THIRD ANGLE PROJECTION

DIMENSIONS ARE IN MILLIMETERS UNLESS OTHERWISE STATED

TO THE LIMITS & TOLERANCES SPECIFIED IN THE CURRENT BS3643 PT2 CLASS 6g EXTERNAL OR 6H INTERNAL

© WIDNEY plc THIS DOCUMENT IS CONFIDENTIAL & THE DOCUMENT & THE COPYRIGHT THEREIN ARE THE PROPERTY OF WIDNEY plc. THE DOCUMENT & ANY INFORMATION THEREIN MAY NOT BE USED, COPIED OR DISCLOSED TO ANY THIRD PARTY WITHOUT THE PRIOR WRITTEN AUTHORISATION OF WIDNEY plc

A3 SCALE