

Many options are available for this lock.
The computer lists the options and part numbers.

Drawn By: P J Thomas		Checked By:	
Date: 27.11.02		Date:	
Issue	Alteration	Date	By
1	Issue	21.05.91	PJT
2	Note 4 added	08.02.94	PJT
3	23 was 25	25.07.94	PJT
4	Notes tidied. Transferred to CAD	27.11.02	PJT

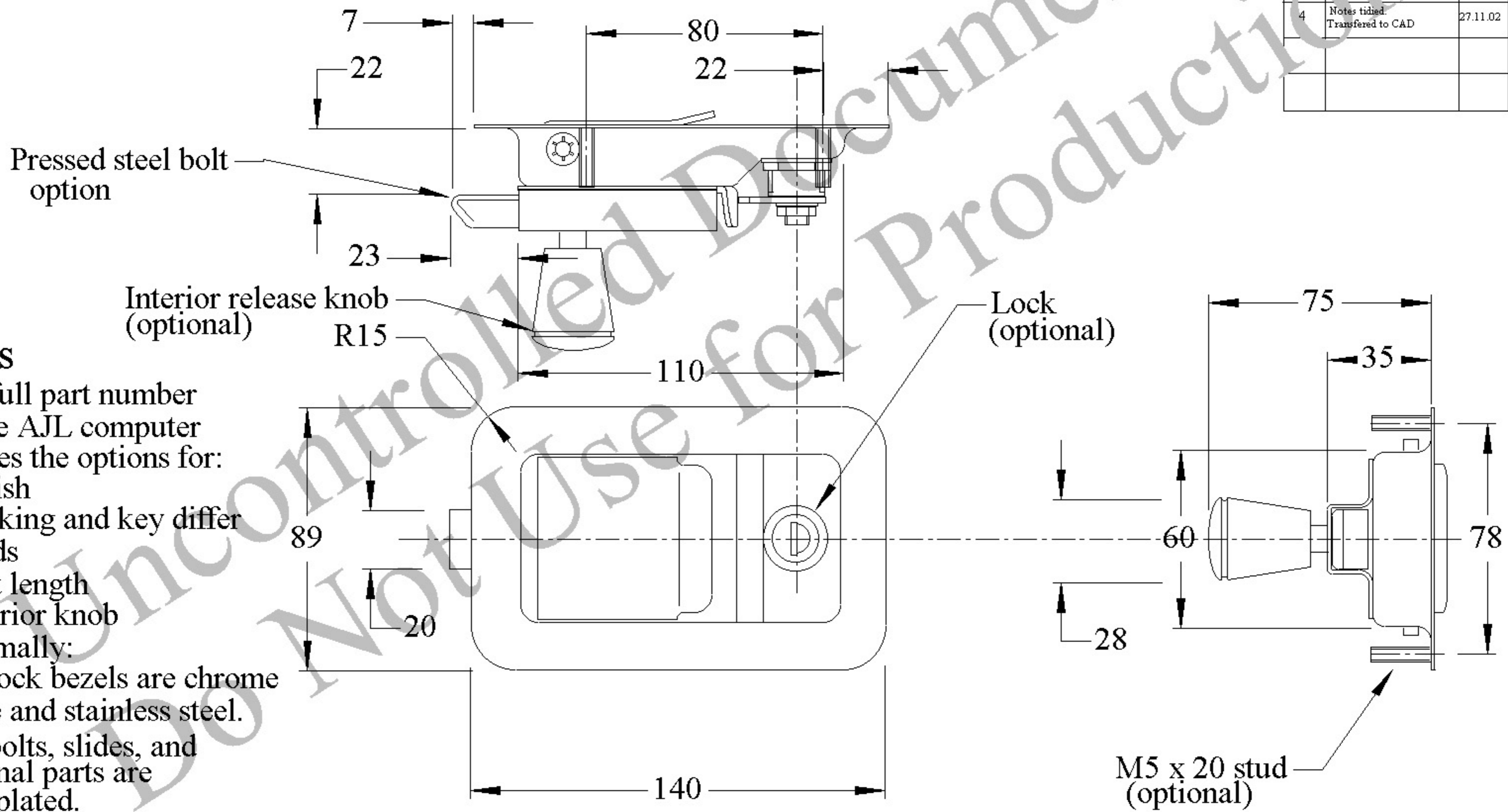

- Notes**
- The full part number on the AJL computer defines the options for:
Finish
Locking and key differ
Studs
Bolt length
Interior knob
 - Normally:
All lock bezels are chrome plate and stainless steel.
All bolts, slides, and internal parts are zinc plated.

This drawing and its copyright belongs to:
Albert Jagger Ltd
Green Lane
Walsall
West Midlands
WS2 8HG
Phone: 01922 627373
Fax: 01922 648021
E-mail: user@albert-jagger.co.uk

Tolerances for Untoleranced Dimensions	up to 10mm	>10 < 50mm	>50 < 200mm	>200mm
	+/-0.5mm	+/-1.0mm	+/-2.0mm	+/-3.0mm

Material Mild steel	Description: Small flush lock
Finish: Various	Drawing Number: 0907application